



# Quick Quicker *Ather*

Introducing the new 450 Series



**450X**

2.9 kWh & 3.7 kWh Battery

*More thrills. Per second.*

—

0-40 km/h in  
**3.3 sec**

Top Speed  
**90 km/h**

# Designed for *performance*

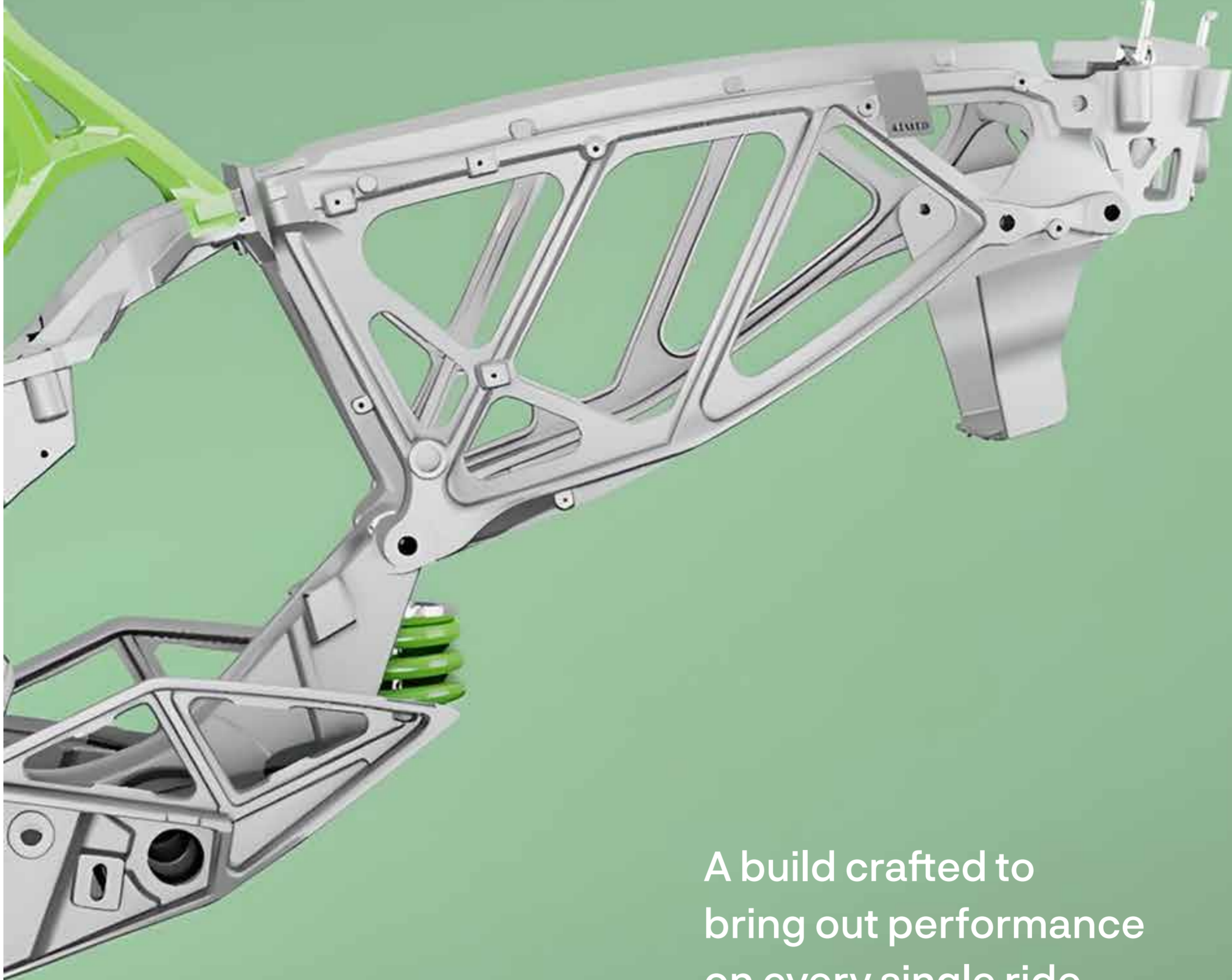

A build crafted to bring out performance on every single ride.

- Lightweight, heavy-duty hybrid aluminium chassis
- Low center of gravity for superior ride handling
- Better stability with rear monoshock suspension
- MRF Zapper Tyres for greater grip in any weather

# More *power* to you

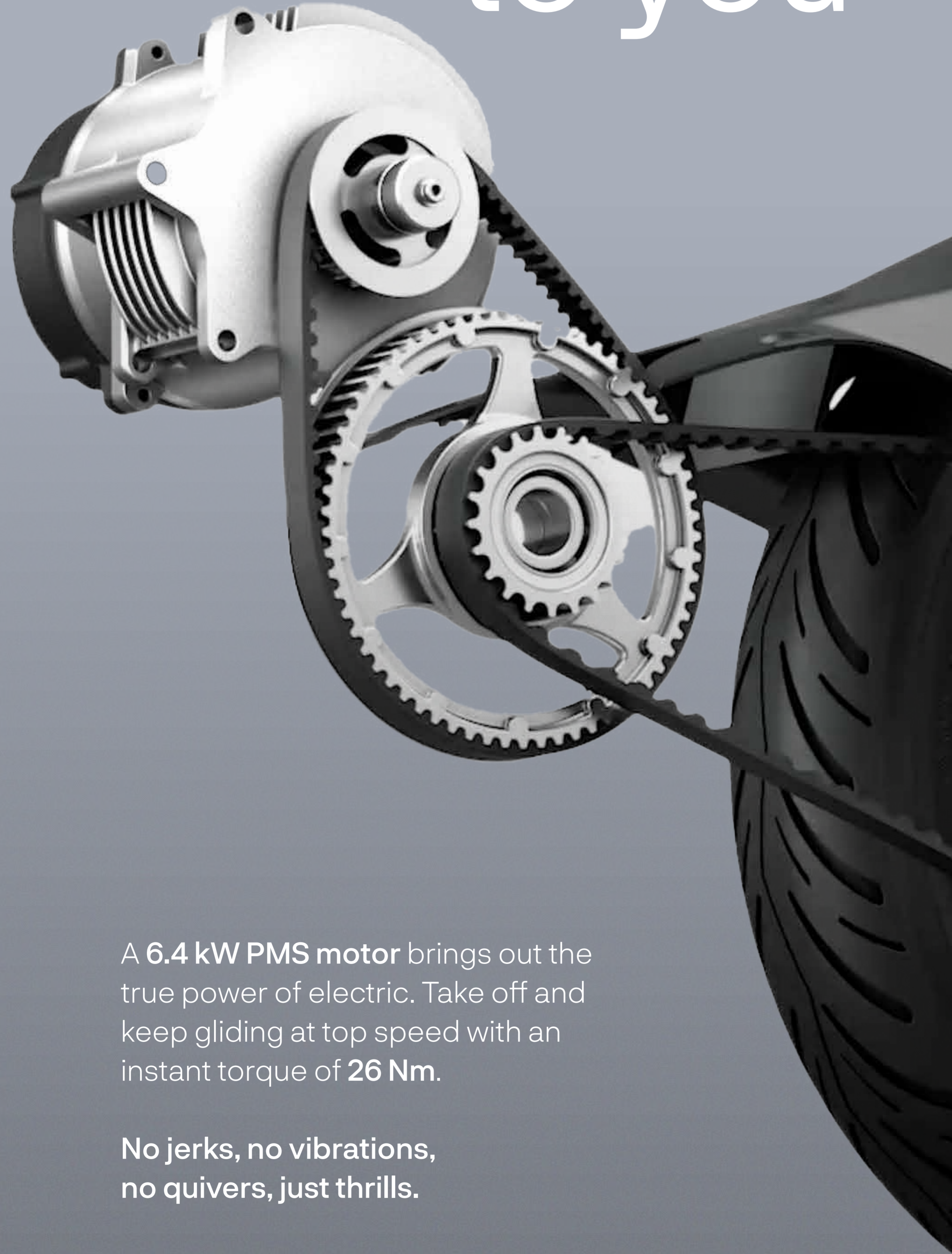

A 6.4 kW PMS motor brings out the true power of electric. Take off and keep gliding at top speed with an instant torque of 26 Nm.

No jerks, no vibrations, no quivers, just thrills.

# A battery that does *brilliantly*



**Stronger,  
lighter, better**

Pressure die-cast aluminium casing

**Water & dust  
resistant**

IP67 rated

**Ather Battery  
Protect™**

- 5 years or 60,000 km warranty
- Minimum 70% State-of-Health for 5 years
- No upper limit on claims
- Deep discharge protection
- 100% coverage against defects or failures

# A dash of *intelligence*



450X

Industry First  
Touchscreen  
Dashboard  
17.7 cm (7")

- Google Maps
- Bluetooth: Call & Music Control
- OTA Updates
- Interactive UI
- TrueRange™: Intelligent Range Prediction
- Document Storage
- Incognito Mode

# One app for everything *Ather*

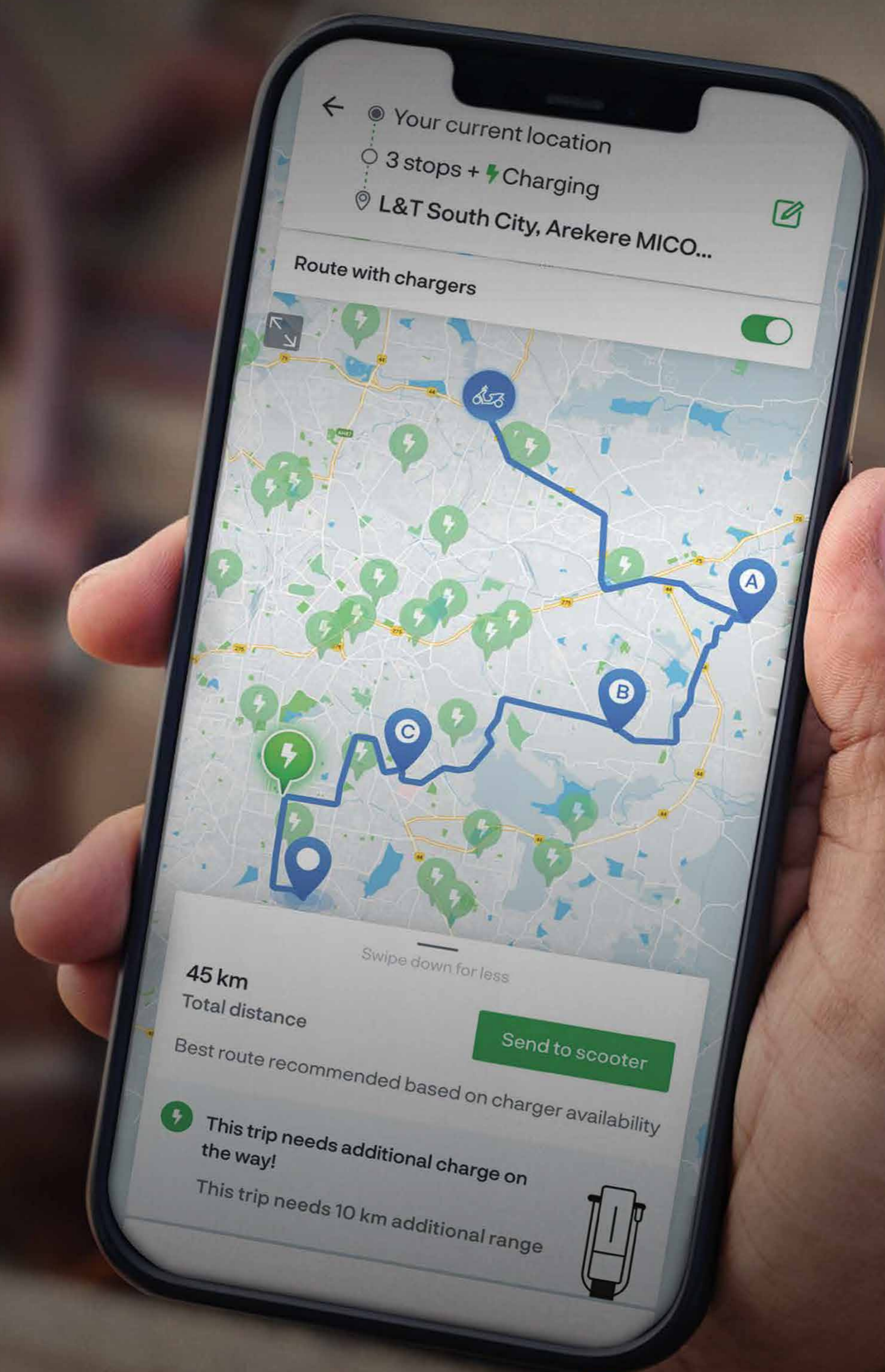

Connectivity  
in the palm of  
your hands

- Theft & tow alerts
- Find my scooter
- Push Navigation
- Savings tracker
- \*Document Storage
- \*Inter-city Trip Planner™

\*Exclusively for 450X

# Convenience comes easy



> Autohold™ Hands-free braking on slopes



> 22L Under Seat Storage

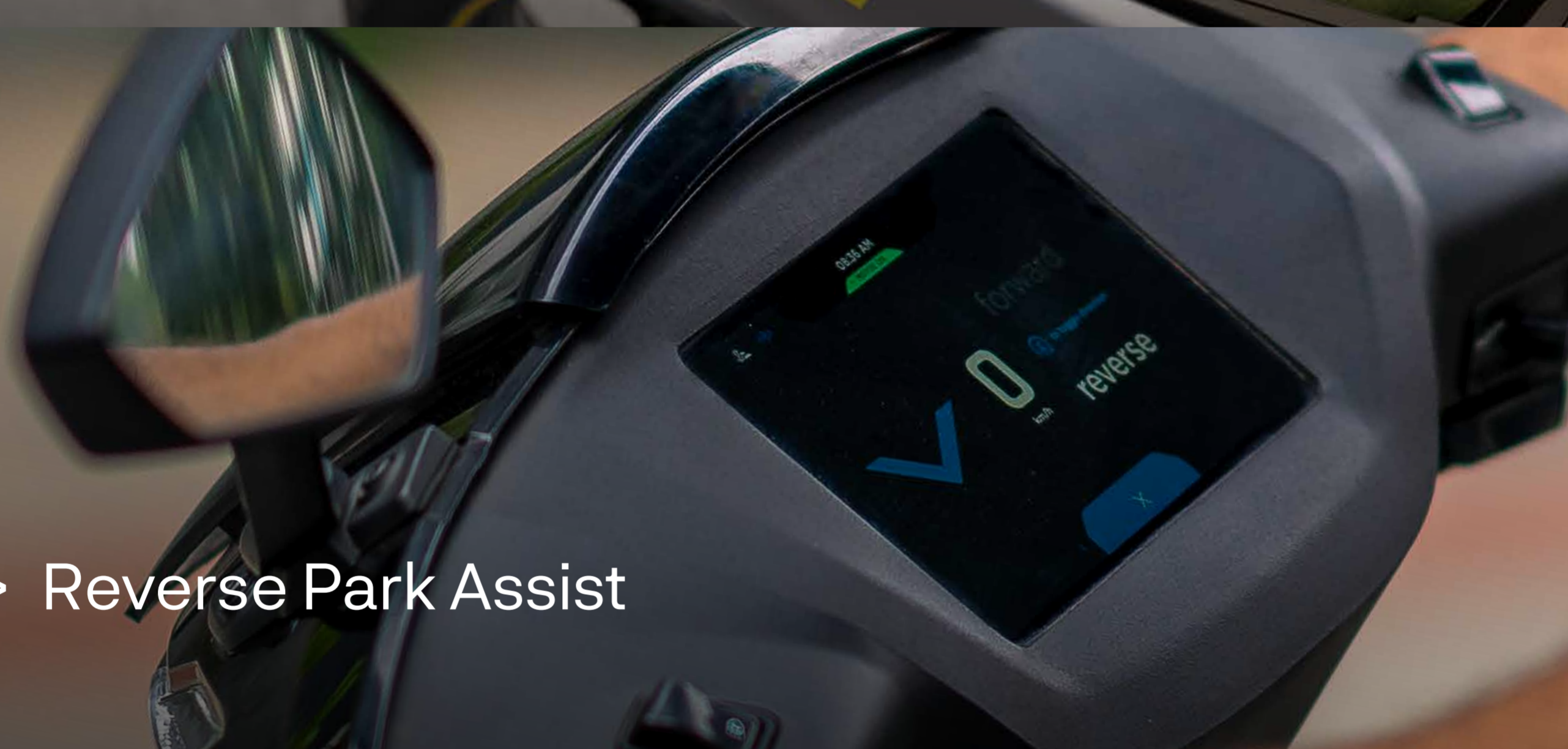

> Reverse Park Assist

> Side Step  
> Auto Indicator  
Cut-off

> Frunk™ (Front storage)  
> Guide-me-home  
lights

# Safety first, second and third

**Emergency  
Stop Signal**

Panic braking will automatically trigger tail light flashing, warning everyone of an emergency situation.

**FallSafe™**

In case of a fall, your Ather will immediately detect it and cut off the motor, protecting you from further danger.

**Dual Disc Brakes**

60 - 0 km/h in <2 seconds

# Flying colours.

## Now on the road.

-  True Red\*
-  Salt Green
-  Lunar Grey\*
-  Cosmic Black
-  Still White
-  Space Grey



\*Exclusively for 450X

# Stay in charge whenever, wherever



**1400+**  
**Ather Grid™**  
**points**

India's largest & fastest growing charging network

**Ather**  
**Portable**  
**Charger**

Plugs into any 5A socket whether at home or away

# Top up your experience with *Ather Accessories*

## Ather Helmets

Head to wheels, colour coordinated.

## Ather TPMS (Tyre Pressure Monitoring System)

Low or high, it tells you when the tyre pressure isn't right.

## Ather Side Step

There when you need it. Invisible when you don't.

## Ather Frunk™

Store. Much more.

On-the-go.



# Ather *Essentials*

The must-have kit to keep your ride protected and looking new for longer.

## > Ather BodyGuard

Catches all scratches before they hit your scooter.

## > Floor Mats

Put your foot down against dirt-ridden floors.

Fits perfectly, cleans easily.

## > Seat Covers

Just wear and don't worry about tear.

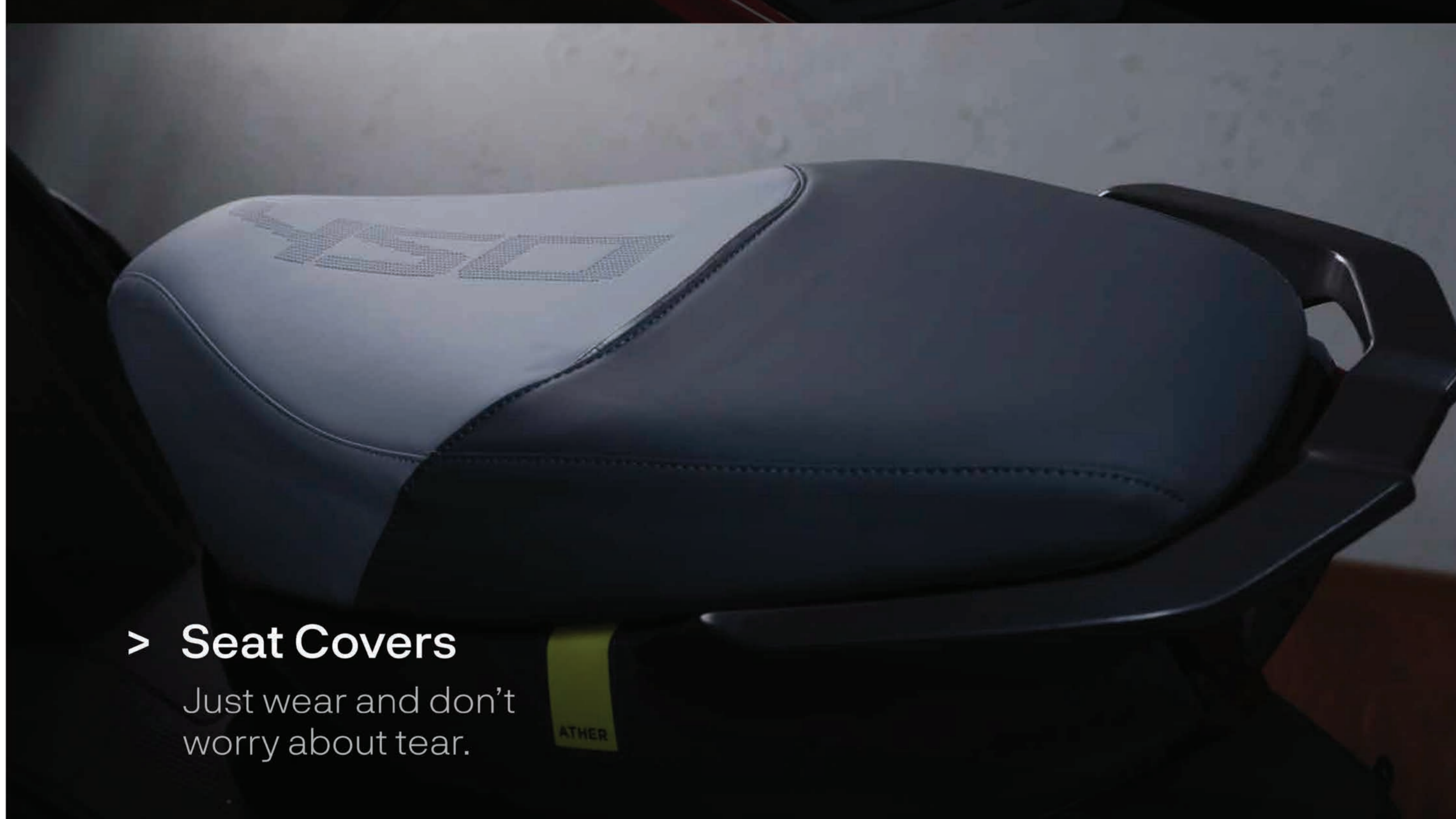
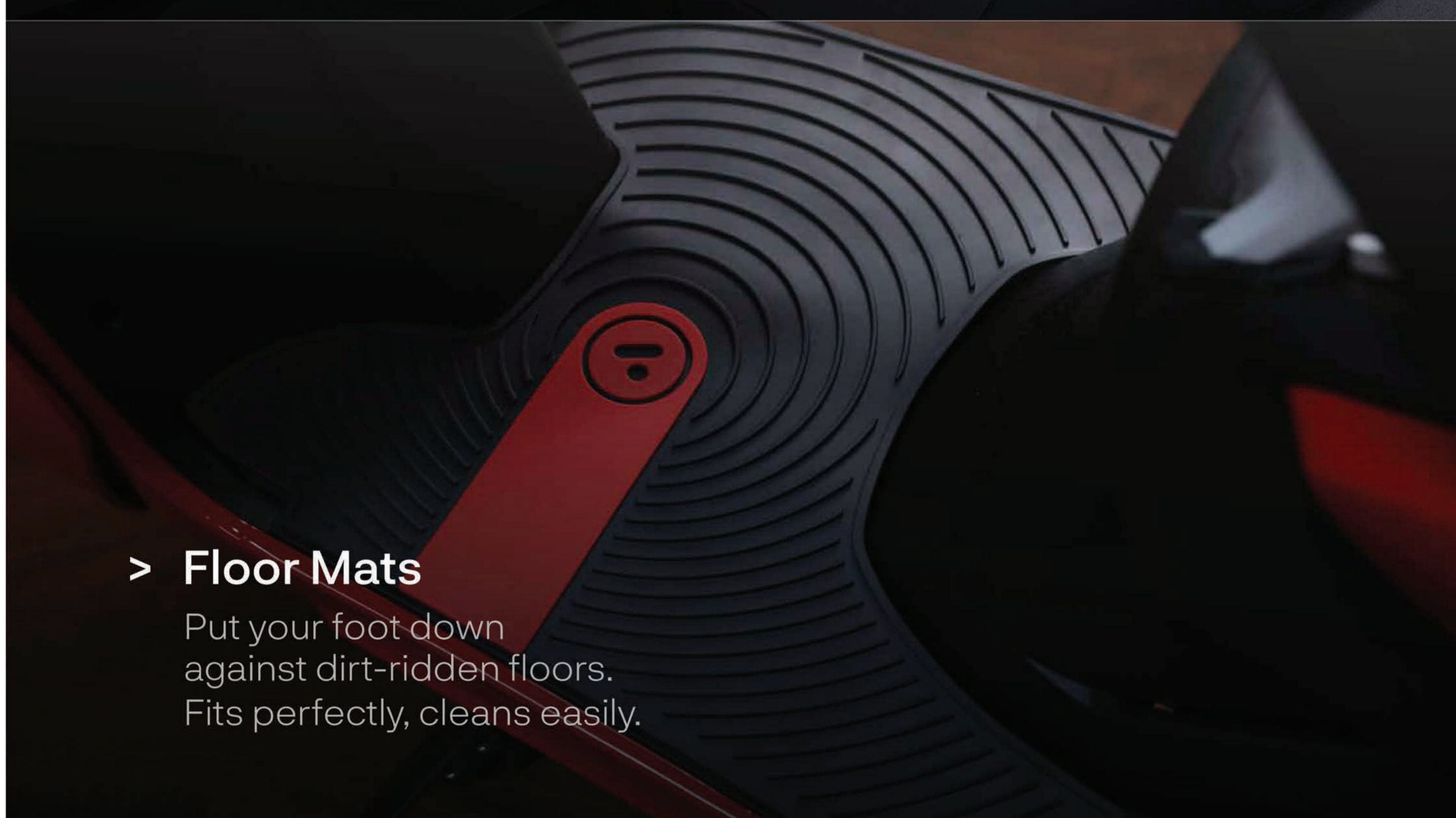

# Made of Ather *Merchandise*



# Specifications & features



2.9kWh Battery



3.7kWh Battery

## Performance

Power (peak)	6.4 kW	6.4 kW
Max torque	26 Nm	26 Nm
Top speed	90 km/h	90 km/h
Acceleration (0-40 km/h)	3.3 s	3.3 s
Gradeability at peak power	20 degrees	20 degrees
Motor type	PMSM	PMSM
Ingress protection (motor)	IP66	IP66
Ingress protection (controller)	IP65	IP65

## Range

Certified Range*	111 km	150 km*
------------------	--------	---------

## Battery

Installed capacity	2.9 kWh	3.7 kWh
Battery type	Lithium-ion	Lithium-ion
Nominal voltage	51.1V	51.1V
Water & dust resistance	IP67	IP67
Pack casing	Aluminium alloy	Aluminium alloy

## Charging

Home Charging*		
0-80%	6 hr 36 min	4 hr 30 min
0-100%	8 hr 36 min	5 hr 45 min

## Tyres & wheels

Wheel type	Alloy wheels	Alloy wheels
Wheel size (front)	30.4 cm x 5.4 cm (12"x 2.15")	30.4 cm x 5.4 cm (12"x 2.15")
Wheel size (rear)	30.4 cm x 6.3 cm (12"x 2.5")	30.4 cm x 6.3 cm (12"x 2.5")
Tyre size (front)	90/90-12 tubeless tyres	90/90-12 tubeless tyres
Tyre size (rear)	100/80-12 tubeless tyres	100/80-12 tubeless tyres

## Brakes

Braking system	Combined braking system & regenerative braking
Brake type (front)	Hydraulically actuated triple-piston calliper disc
Brake type (rear)	Hydraulically actuated single-piston calliper disc
Disc size (front)	20 cm
Disc size (rear)	19 cm
Braking distance (60-0 km/h)	28.6 m

## Transmission

Type	Belt drive
Transmission ratio	7.8:1

## Suspension & frame

Front suspension	Telescopic forks
Rear suspension	Symmetrically mounted progressive monoshock
Frame type	Precision machined hybrid chassis
Frame materials	Aluminium and steel

## Peripherals & convenience

Headlights	LED
Taillights	LED
Indicators	LED
Park Assist™	Yes
Side stand motor cut-off	Yes
Boot storage	22L
Pillion grab handle	Aluminium

## Dimensions & storage

Length	189.1 cm	189.1 cm
Width	73.9 cm	73.9 cm
Height	111.4 cm	111.4 cm
Wheelbase	129.6 cm	129.6 cm
Ground clearance	17 cm	17 cm
Seat height	78 cm	78 cm
Kerb weight	108 kg	111.6 kg
F:R weight ratio	48:52	48:52
Water wading limit	30 cm	30 cm

## Dashboard

Processor	Snapdragon 212	Snapdragon 212
	Quadcore 1.3Ghz	Quadcore 1.3Ghz
Storage	16GB	16GB
RAM	2GB	2GB
Operating system	Android Open Source	Android Open Source
	OS (AOSP)	OS (AOSP)
Screen size & type	17.7 cm (7")	17.7 cm (7")
	TFT touchscreen	TFT touchscreen
Touchscreen type	Capacitive	Capacitive
Resolution	800 x 480 pixels	800 x 480 pixels
Colours	16M	16M
Brightness	800 Nits	800 Nits
Aspect ratio	5:3	5:3
Water & dust resistance	IP65	IP65

## Colours

	Space Grey, Still White, Salt Green, True Red, Cosmic Black, Lunar Grey™	Space Grey, Still White, Salt Green, True Red, Cosmic Black, Lunar Grey™
--	--	--

## Warranty

Vehicle warranty	5 years/60,000km whichever is earlier
Charger warranty	3 years
Battery warranty	5 years/60,000km whichever is earlier

## Unlock all the smarts, all the intelligence

## RideAssist™

Riding modes	5	5
TrueRange™ Display	SmartEco™ - 90 km Eco - 85 km Ride - 75 km Sport - 70 km Warp™ - 60 km	SmartEco™ - 110 km Eco - 105 km Ride - 90 km Sport - 85 km Warp™ - 75 km
Interactive UI	Yes	Yes
Dashboard auto brightness	Yes	Yes
AutoHold™	Yes	Yes
Auto Indicator cut-off	Yes	Yes
Guide-me-home lights	Yes	Yes
Vehicle FallSafe™	Yes	Yes
Coasting Tracker	Yes	Yes
Emergency Stop Signal (ESS)®	Yes	Yes
Call & Music control	Yes	Yes

## Ather Connect™

Complimentary for 2 years

Navigation	Google Maps	Google Maps
Document Storage	Yes	Yes
Towr App™ features	Yes	Yes
Anti-Theft Notifications	Yes	Yes
Find my scooter	Yes	Yes
Ride Stats	Yes	Yes
Push Navigation	Yes	Yes
Inter-city Trip Planner™	Yes	Yes
Savings trackers	Yes	Yes
Ather Labs™	Yes	Yes

## Atherstack™

OTA Updates	Yes	Yes
-------------	-----	-----



[atherenergy.com.np](https://atherenergy.com.np)

☎ 9851354100, 9851321891

Ananda Nagar, Dhumbarai, Kathmandu, Nepal